

TTS-8000

UK Model



DIRECT DRIVE TURNTABLE

SPECIFICATIONS

GENERAL

Power Requirements: 220 or 240V ac, 50/60 Hz
Power Consumption: 14 W
Dimensions: Approx. 370 (w) x 130 (h) x 395 (d) mm
14 ⁹/₁₆ (w) x 5 ¹/₈ (h) x 15 ⁹/₁₆ (d) inches
including projecting parts and controls
Weight: Approx. 9.9 kg, 4 lb 8 oz (net)
Approx. 11.5 kg, 5 lb, 3 oz (with shipping carton)

TURNTABLE

Platter: 32cm (12 ⁵/₈ inches), diecasting aluminum alloy
Drive System: DC servo-controlled motor (brushless and slotless) direct drive, crystal lock control system

Speeds: 33 ¹/₃, 45 rpm.
Speed Control Range: ±4% (crystal lock switch OFF)
Starting Characteristics: at nominal speed within a third revolution (33 ¹/₃ rpm.)
Wow and Flutter: ±0.04% (DIN), 0.025% (WRMS)
S/N Ratio: Greater than 70 dB (DIN-B)

	Position of the Crystal Lock Switch	
	ON	OFF
Initial drift	within 0.0005%	within 0.1%
Load characteristics (at 3 g tracking-force)	0%	less than 0.05%
Speed deviation	within 0.003%	variable

SAFETY-RELATED COMPONENT WARNING!!

COMPONENTS IDENTIFIED BY SHADING ON THE SCHEMATIC DIAGRAMS AND IN THE PARTS LIST ARE CRITICAL TO SAFE OPERATION. REPLACE THESE COMPONENTS WITH SONY PARTS WHOSE PART NUMBERS APPEAR AS SHOWN IN THIS MANUAL OR IN SUPPLEMENTS PUBLISHED BY SONY.

SONY®

SERVICE MANUAL

SECTION 1
BLOCK DIAGRAM

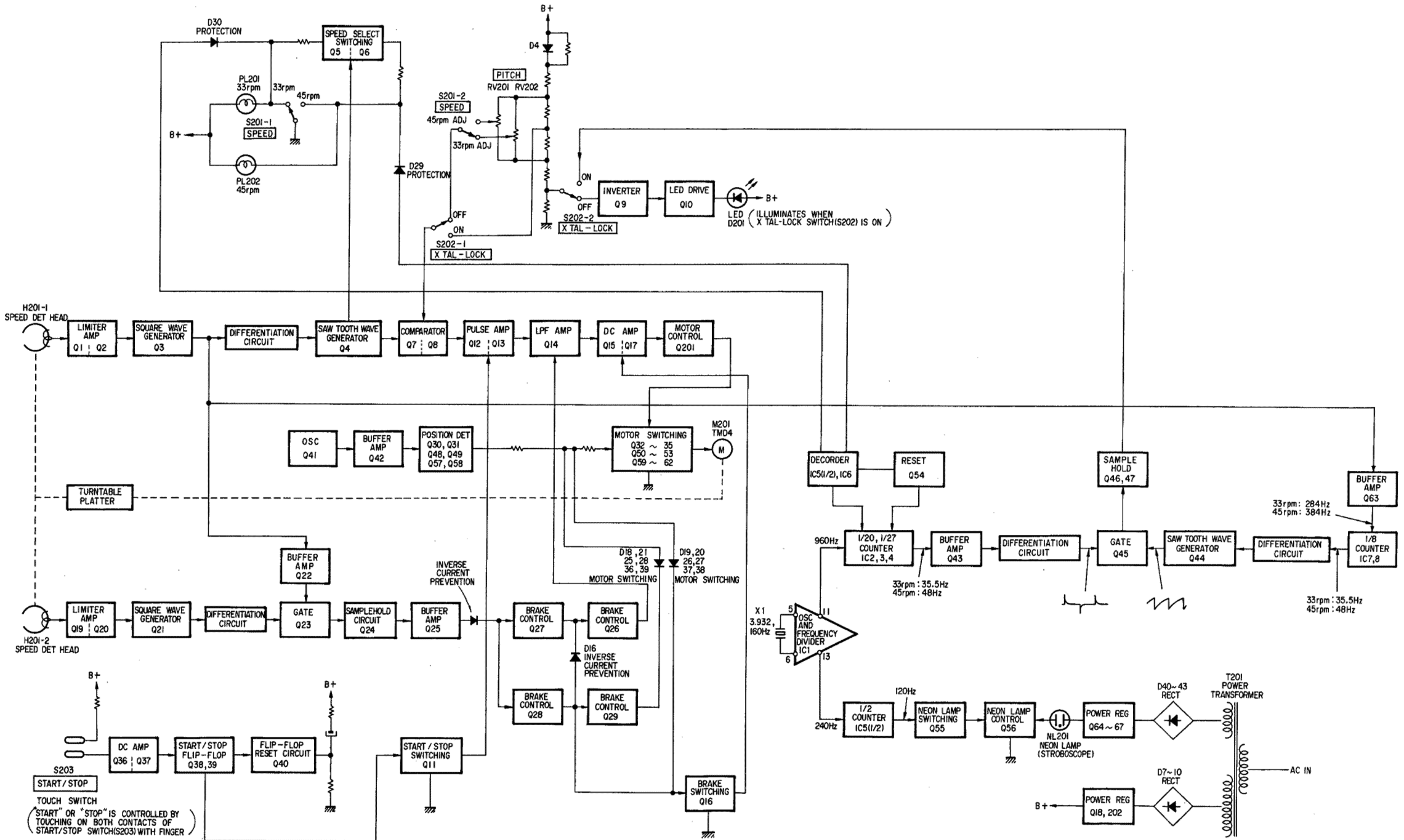

**SECTION 2
DISASSEMBLY**

CAUTION:

- Do not bring a magnetized screwdriver close to the magnetic coating surface.

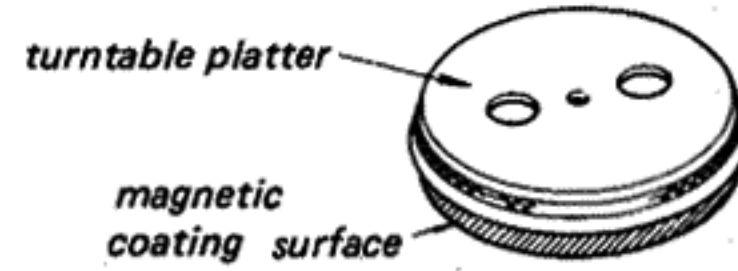

Turntable Platter Removal

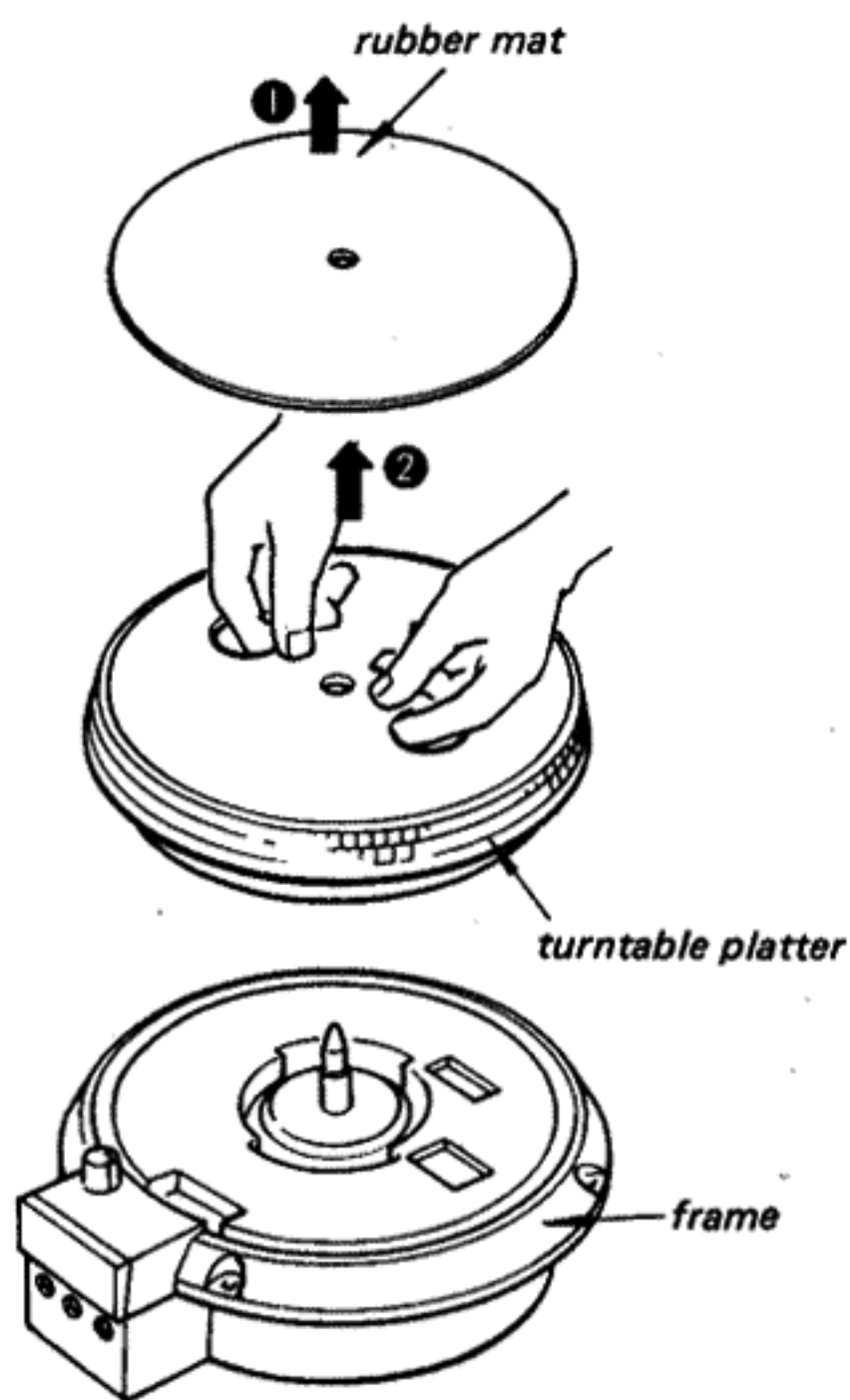

Servo Amp Circuit Board and Control Section Removal

- ① : Servo Amp Circuit Board
- ② : Control Section

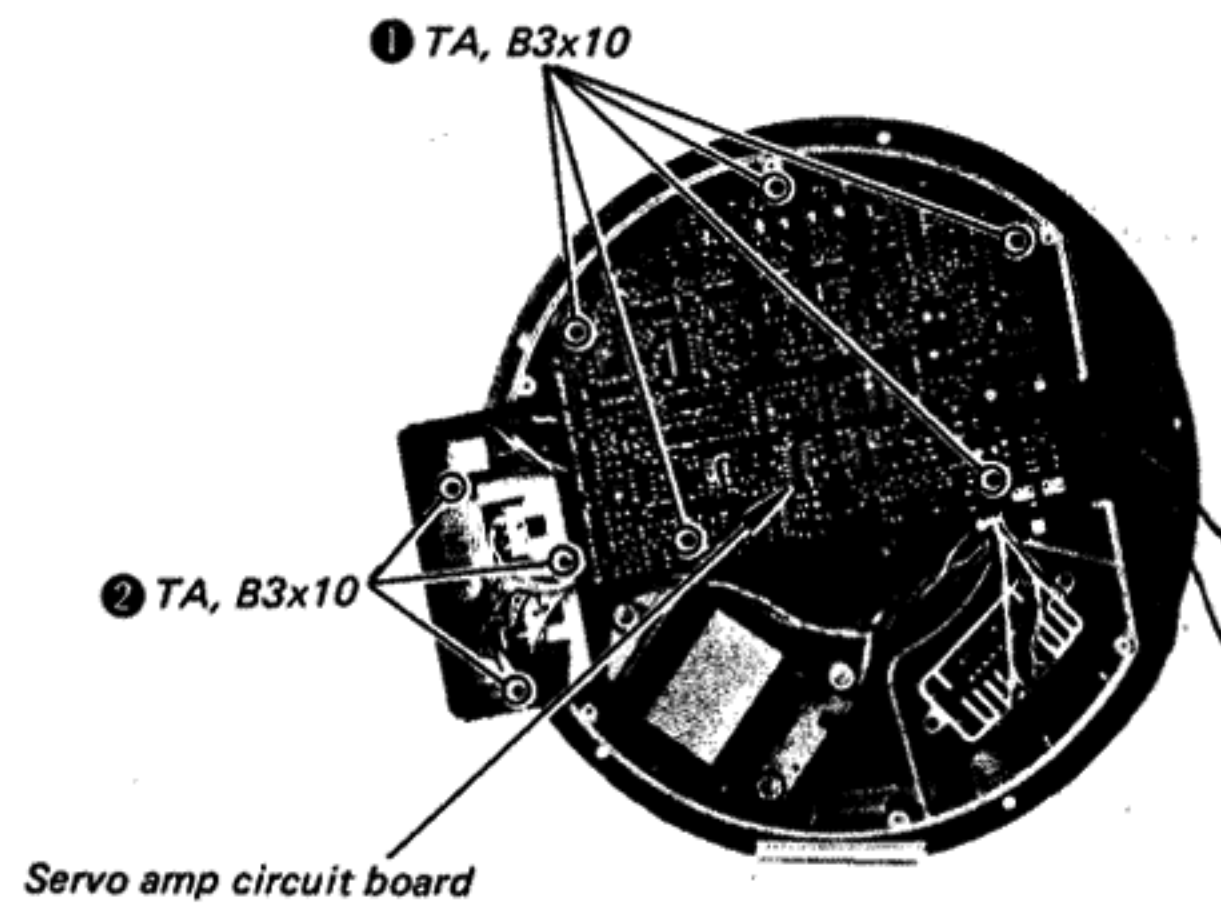

Bottom Plate Removal

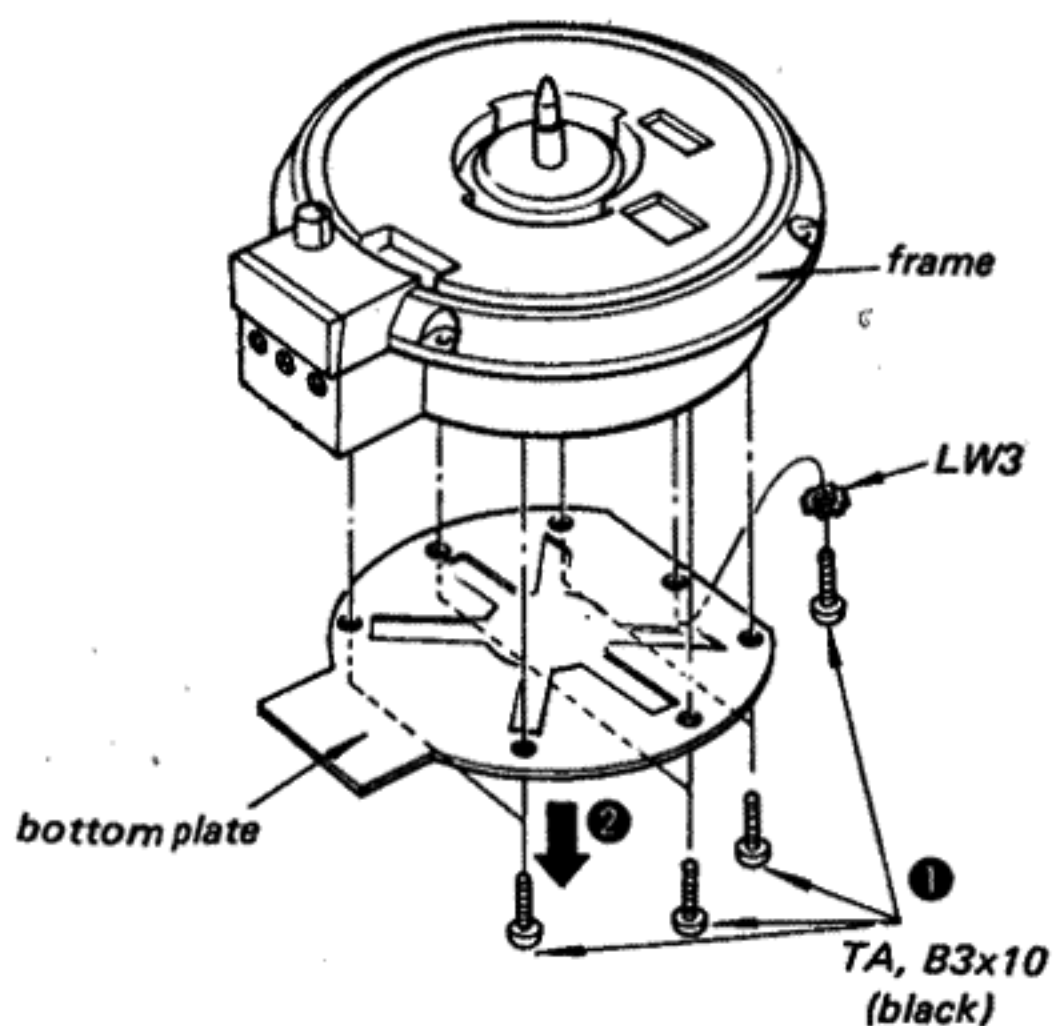

Replacement

- Neon Lamp (with lamp holder)
- SPEED Switch
- XTAL-LOCK Switch
- Pilot Lamp
- LED

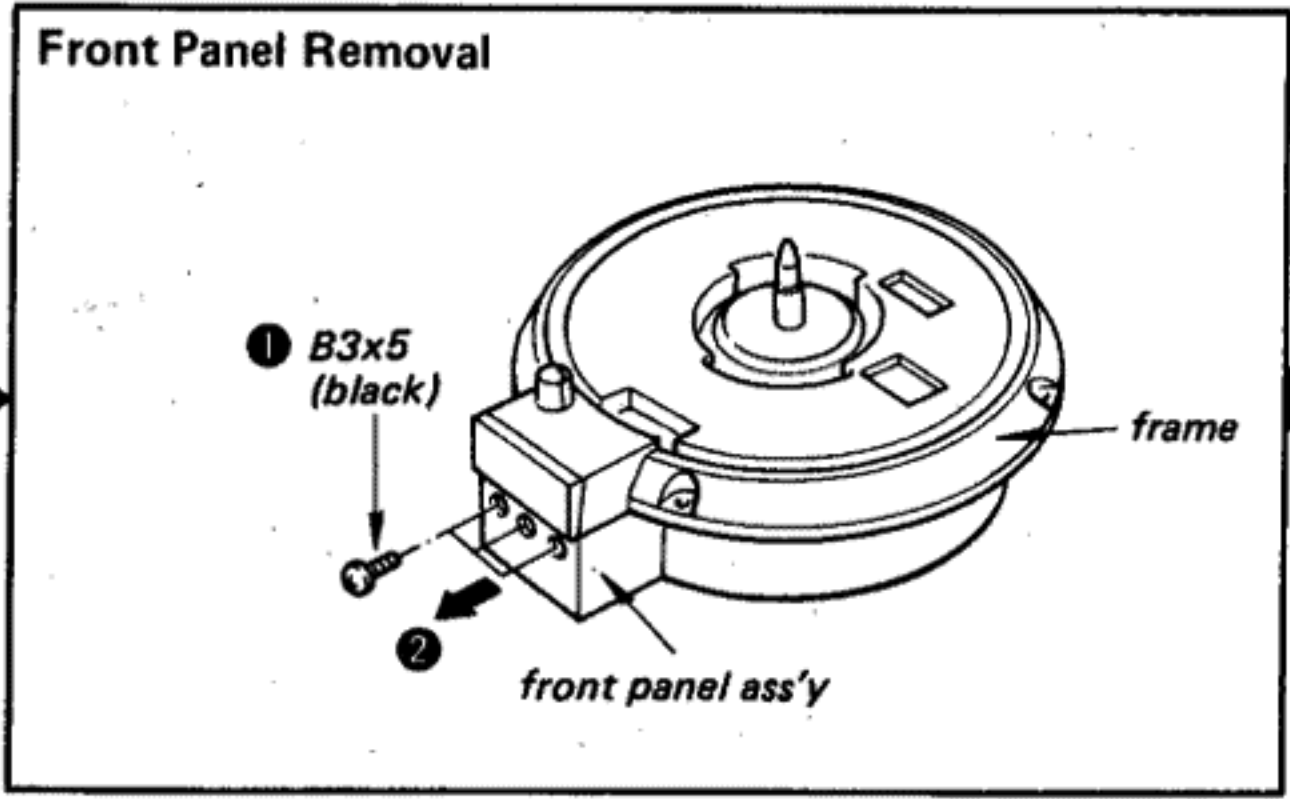

- ### Replacement
- Microswitch (POWER)
 - Variable Resistor (PITCH)

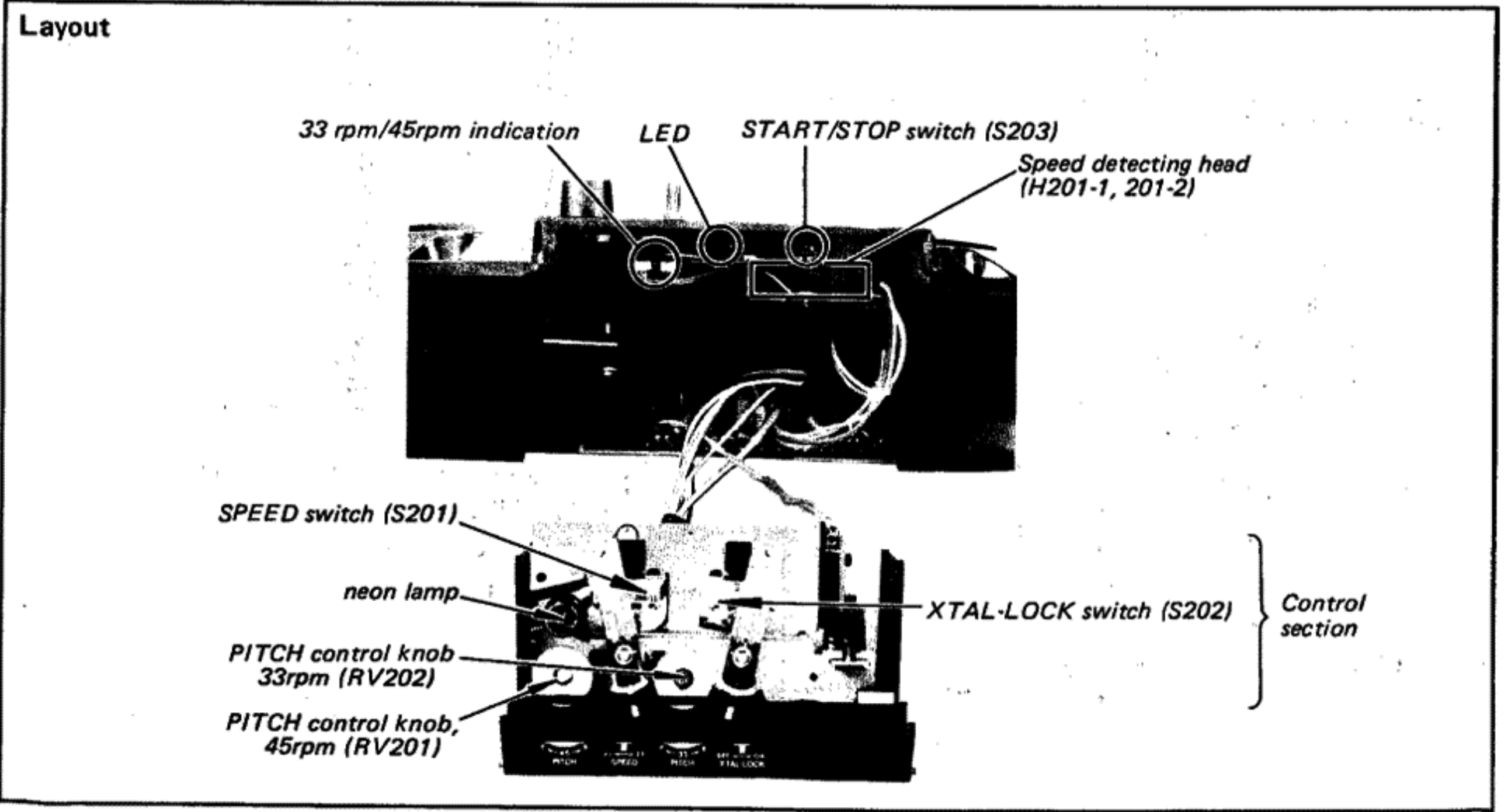
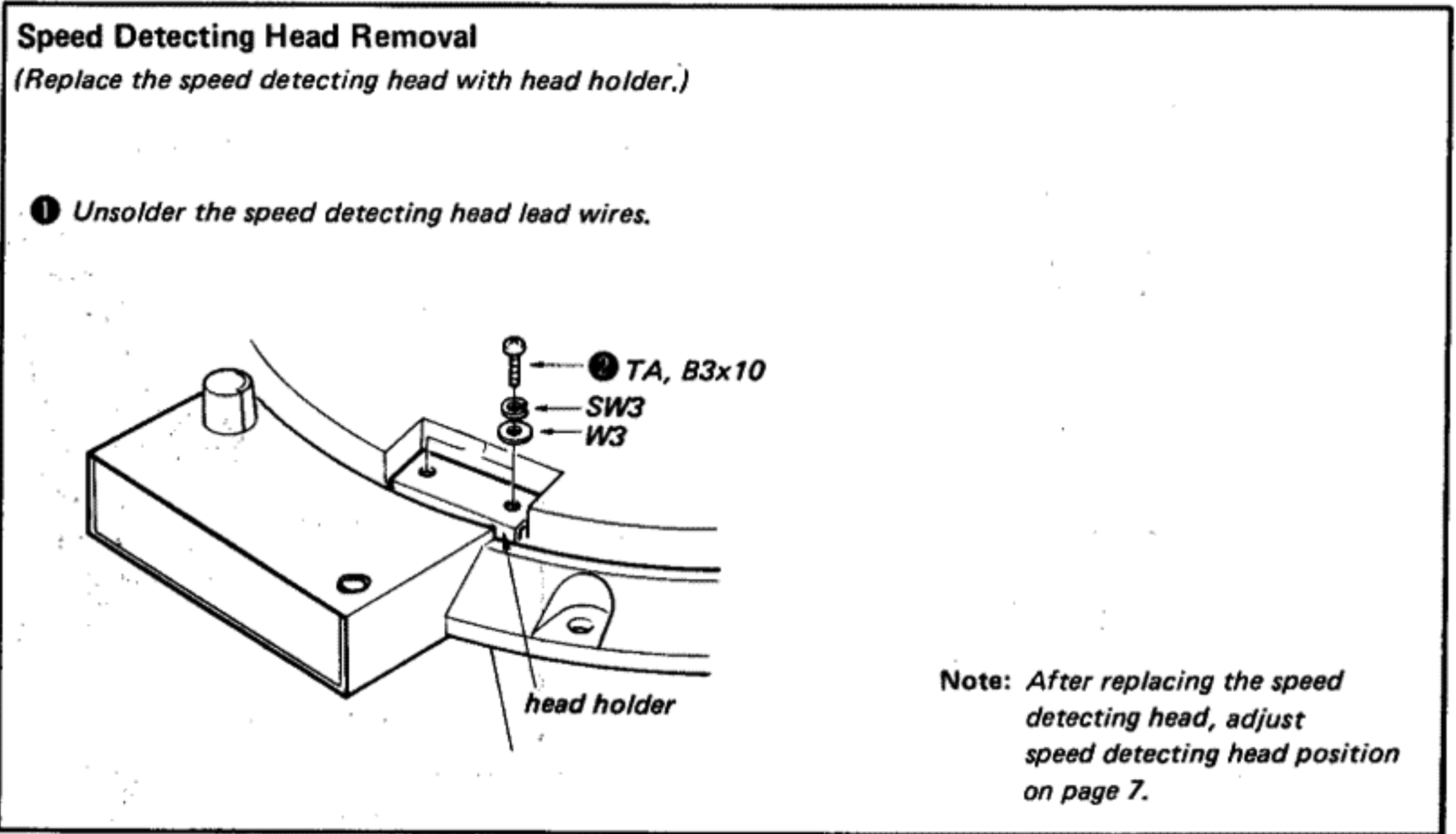

SECTION 3 ADJUSTMENTS

3-1. SPEED DETECTING HEAD POSITION ADJUSTMENT

When replacing the speed-detecting head and the turntable platter, adjust them as follows. Maladjustment results in insufficient servo operation or abnormal wow-flutter characteristics.

Procedures:

- 1). Remove the turntable platter. (on page 5)
- 2). Remove the control section. (on page 5)
- 3). Position the head holder in the direction shown by the arrow in Fig. 1 sufficiently. Fix the head holder (assembled with the speed detecting head) to the frame temporarily.

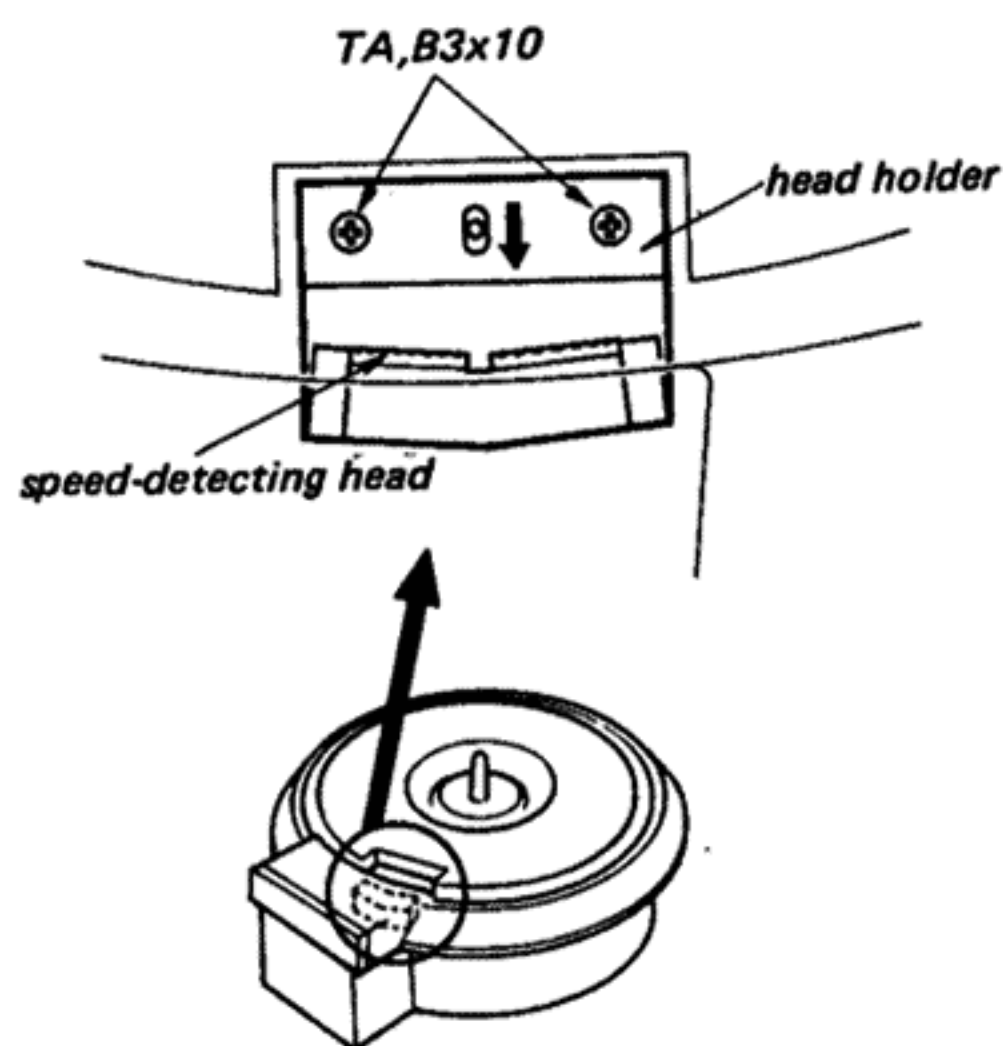

Fig. 1

- 4). Adhere the card (approx. 0.3mm thick) onto the magnetic coating surface of turntable platter as shown in Fig. 2.

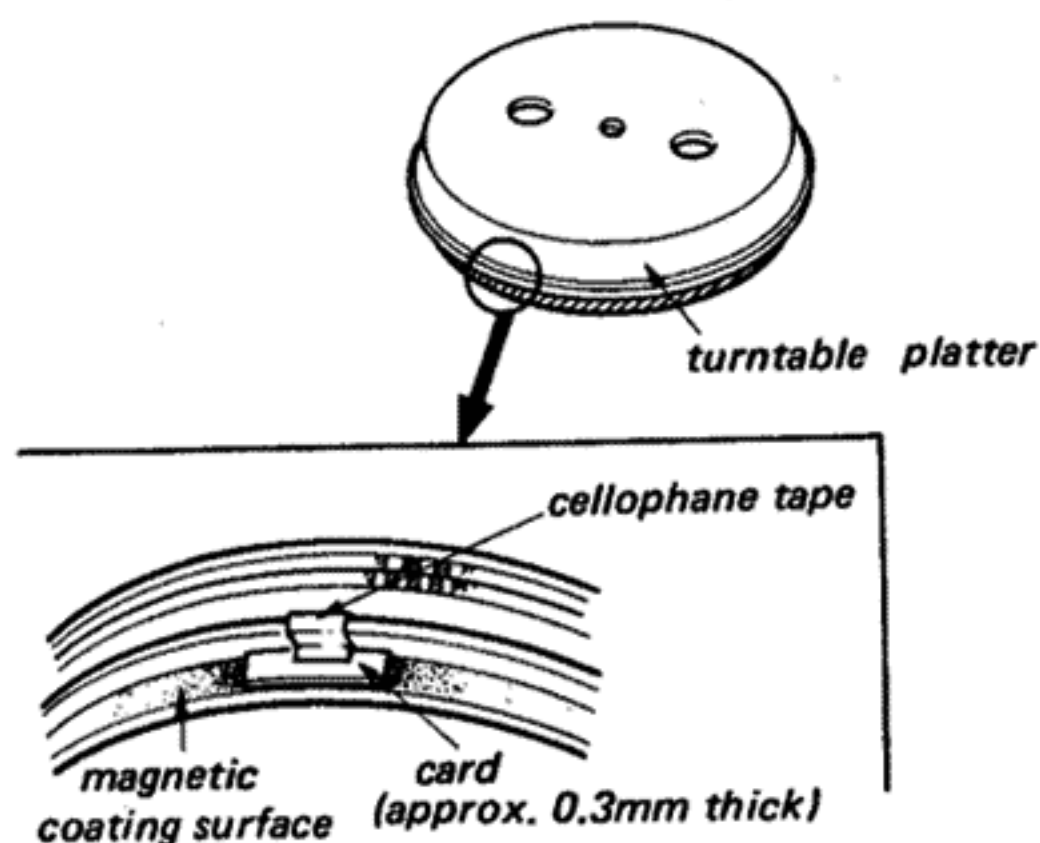

Fig. 2

- 5). Install the turntable platter with the card faced to the heads.
- 6). Move the head holder to the turntable platter side so that the two heads evenly contact the card.
- 7). Remove the turntable platter carefully, and then secure two setting screws of the head holder.
- 8). Remove the card from the turntable platter, and confirm that the turntable platter does not contact the head after installing the turntable platter again.
- 9). Turn the power switch on. Confirm that the stripe of stroboscope seems to be stopped at speeds of 33 rpm and 45 rpm. Confirm that the output level is 30 to 60 mV ac on the VTVM connected to the terminal of head, and also the output level of two heads is almost the same. If not, readjust the position of the head holder.

3-2. TURNTABLE SPEED ADJUSTMENT

If correct speed cannot be obtained by adjusting the pitch controls, adjust R16 and R18.

- 1). Set the two pitch control knobs (33 and 45) to the mechanical-mid-position.
- 2). Adjust R16 (33 rpm) and R18 (45 rpm) so that the stroboscope pattern appears stationary.

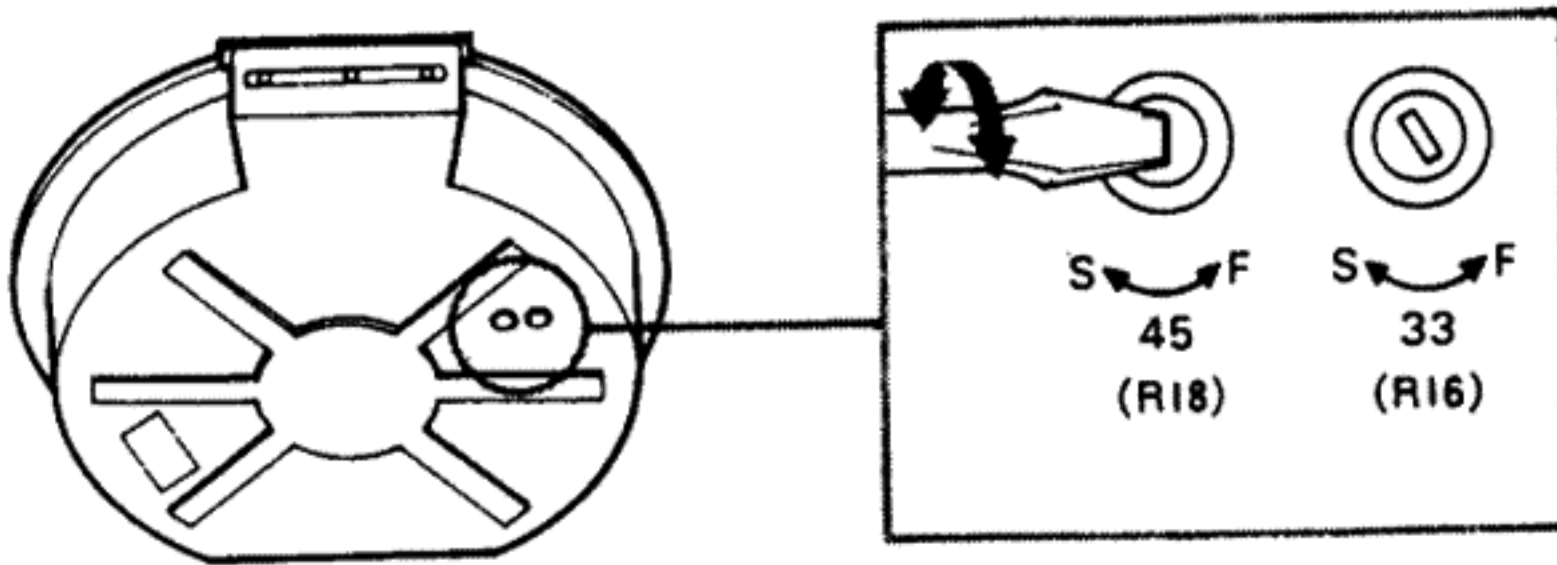

Fig. 3

SECTION 4 DIAGRAMS

4-1. MOUNTING DIAGRAM — Conductor Side —

Semiconductors

For replacement, use semiconductors except in ().

Q1~4, 7~11 : }
14~16, 18~33 : } 2SC634A
36~51, 54, 55 : }
57~60, 63, 65 : }
68 : }

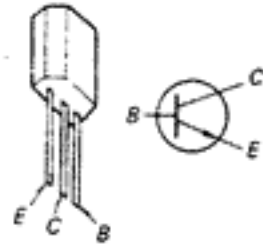

(2SC945)

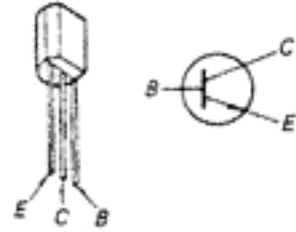

Q67: 2SC1431

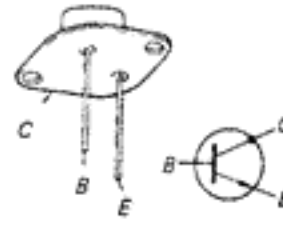

Q5, 6 : }
12, 13 : } 2SA678
17 : }

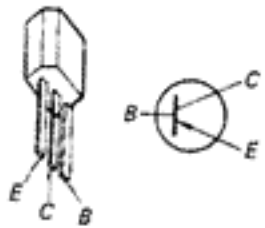

(2SA733)

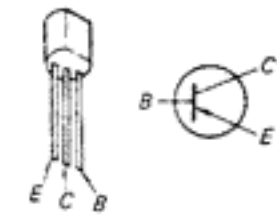

Q69: 2SK30A

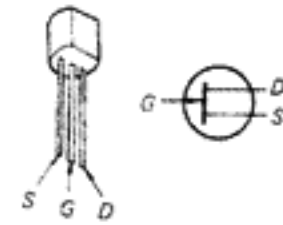

Q34, 52, 61 : }
201, 202 : } 2SC1061

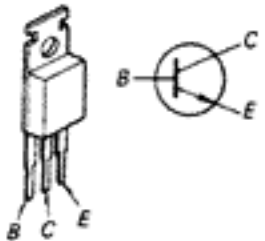

IC1: MSM5576
IC2, 4, 5, 6, 7, 8: M53200P
IC3: M53210P
IC6: M53220P

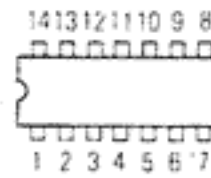

(Top view)

Q35, 53 : }
62 : } 2SA671

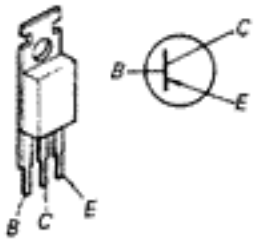

D1~3 : }
5 : } IS1555
11~34 : }
36~39 : }
D7~10 : }
35 : } 10E2
40~43 : }



Q56: 2SC1127

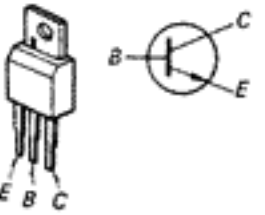

D4: MV5L

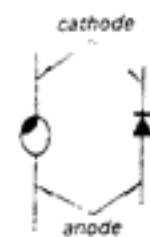

Q64: 2SC1760

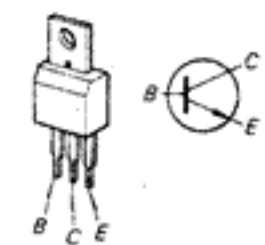

D6, 44: EQB01-06
(EQA01-06S)

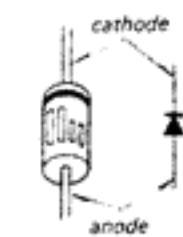

Q66: 2SC926A

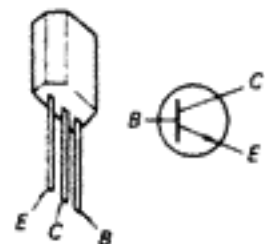

D201: SLP24B

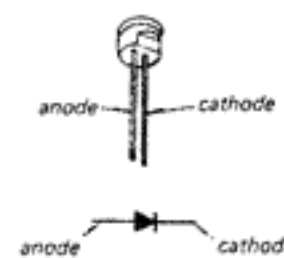

- [Pattern] : component-side pattern
- [Pattern] : B+pattern
- ⊗ : Through hole.
- Color code of sleeving over the end of the jacket.

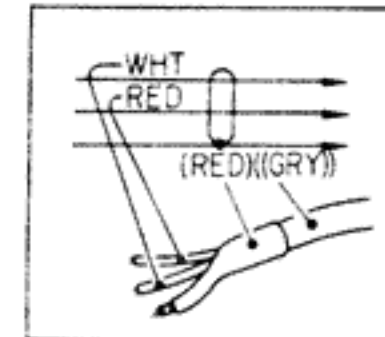

- Readings are taken with a 20,000 ohm-per-volt VOM.
- no mark or : 33 rpm
- no parenthesis
- { } : stop
- [] : 45 rpm
- < > : first time of start
- ◉ : when no touching to S203.
- ▲ : when touching to S203.

[SERVO AMP BOARD]

[TOUCH SWITCH BOARD]

[HEAT SINK BOARD]

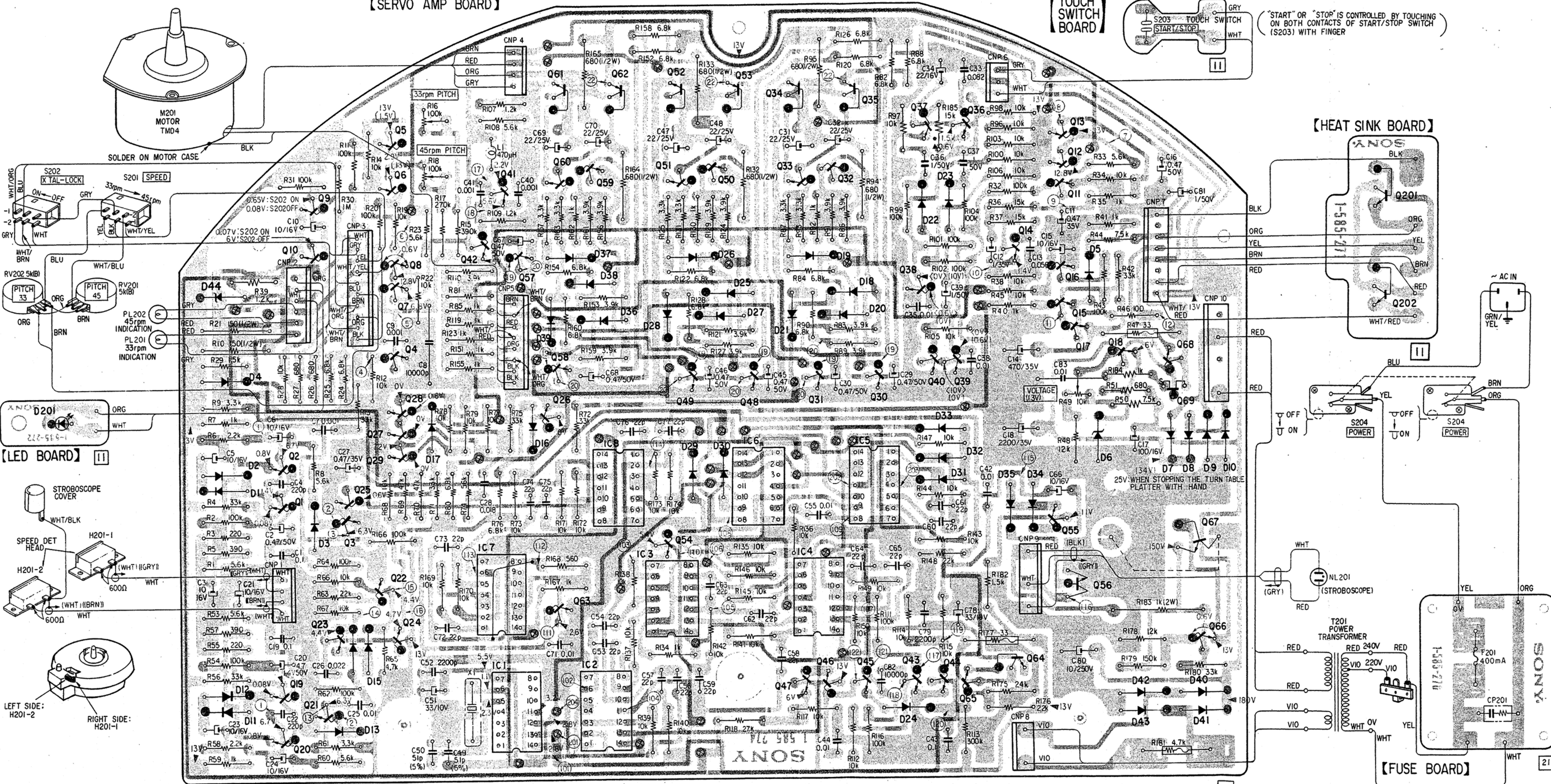

Q	2	9	5	4	41	61	60	59	62	52	53	34	35	37	36	14	12	18	68	67	201						
IC	1	10	23	25	8	28	42	57	58	54	49	48	31	32	30	38	40	39	64	55	17	69	66	202			
D	19	20	3	22	24	26	63	IC7	IC1	IC2	IC3	IC4	IC5	IC6	47	46	45	43	44	65	15	56	5	7	8	9	10
	44	4	3	14	15	17	39	38	36	28	25	19	18	22	23	33	32	35	34	6	42	40	41				
	201	2																									
		1																									
		12																									
		11																									

ohm-per-volt VOM.

o S203.
203.

4-1. SCHEMATIC DIAGRAM

TTS-8000

TTS-8000

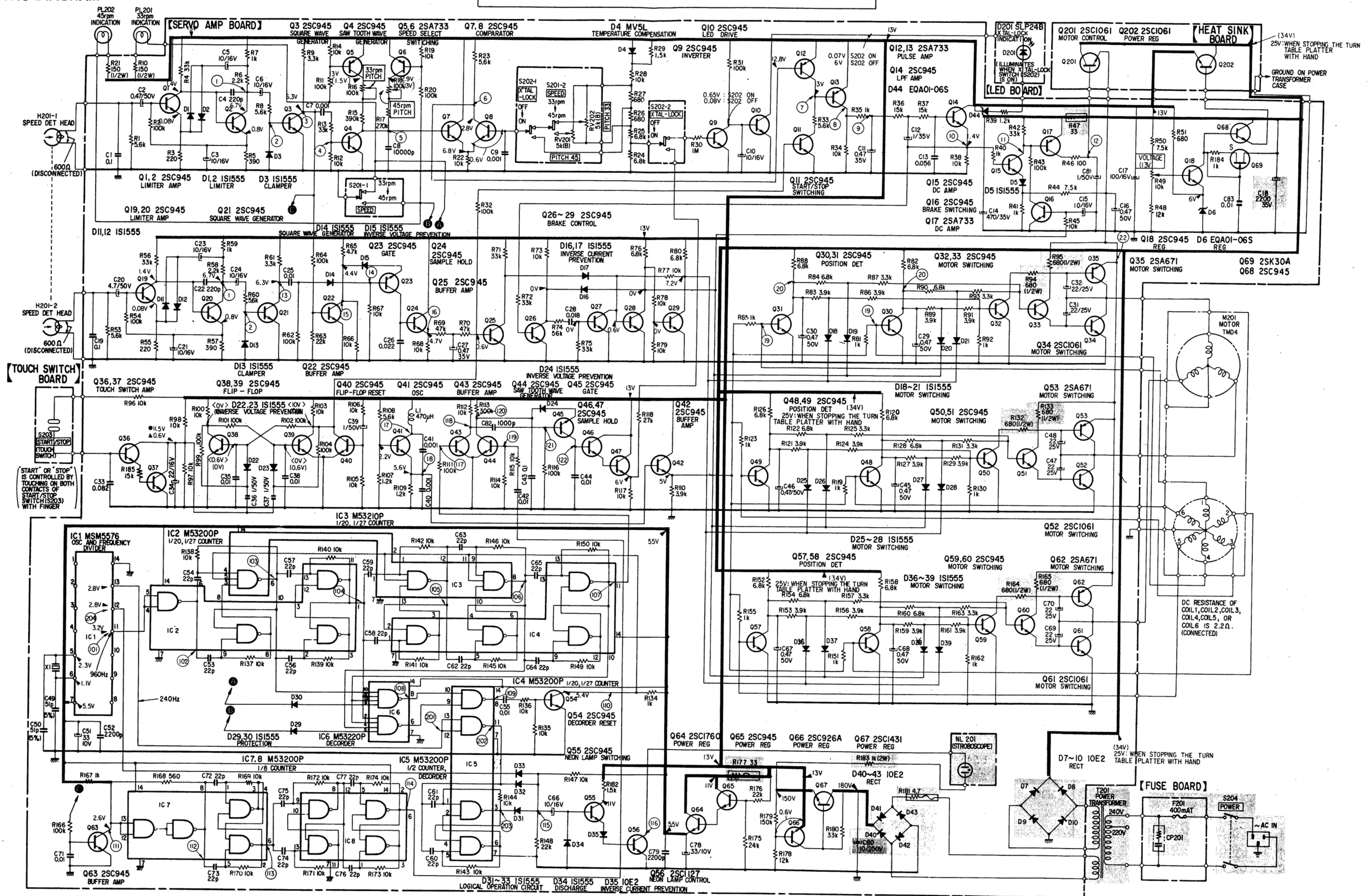

- : B+bus.
- : panel designation.
- : adjustment for repair.
- : direct connection to points marked on the chassis.
- : chassis ground.
- All capacitors are in μF unless otherwise noted, $\text{pF} = \mu\text{F}$. 50WV or less are not indicated except for electrolytics.
- : fusible resistor.

- Voltage variations may be noted due to normal production tolerances.
- DC resistance of speed detecting head (H201-1 or H201-2) measurements are with coils disconnected from circuit board.
- DC resistance of motor coil (1) to coil (6) measurements are with coils connected on the circuit board.
- Circled numbers (1) to (22) refer to waveforms shown on page.
- All resistors are in ohms. $\frac{1}{2}\text{W}$ unless otherwise noted. $\text{k}\Omega = 1000\Omega$, $\text{M}\Omega = 1000 \text{ k}\Omega$
- (2%) and (5%) indicates component tolerance.

- Readings are taken with a 20,000 ohm-per-volt VOM.
- no mark or no parenthesis : 33 rpm
- () : stop
- [] : 45 rpm
- < > : first time of start
- : when no touching to S203.
- ▲ : when touching to S203.

• Switch

Ref. No.	Switch	Position
S201	SPEED	33 rpm
S202	X TAL-LOCK	OFF
S203	START/STOP (TOUCH SWITCH)	
S204	POWER	OFF

Note: The components identified by shading are critical for safety. Replace only with part number specified.

Wave of the speed detecting head (H201)

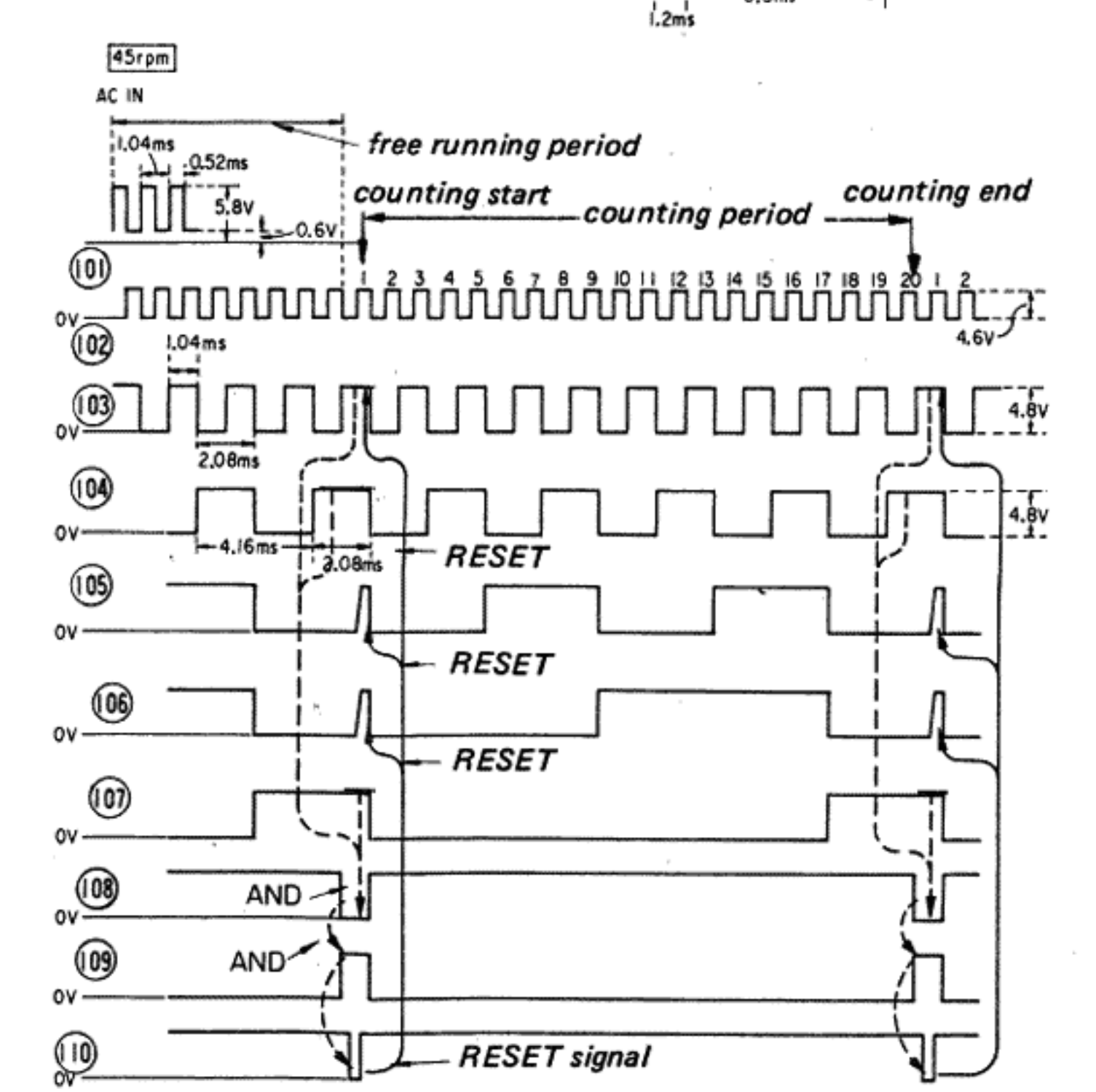
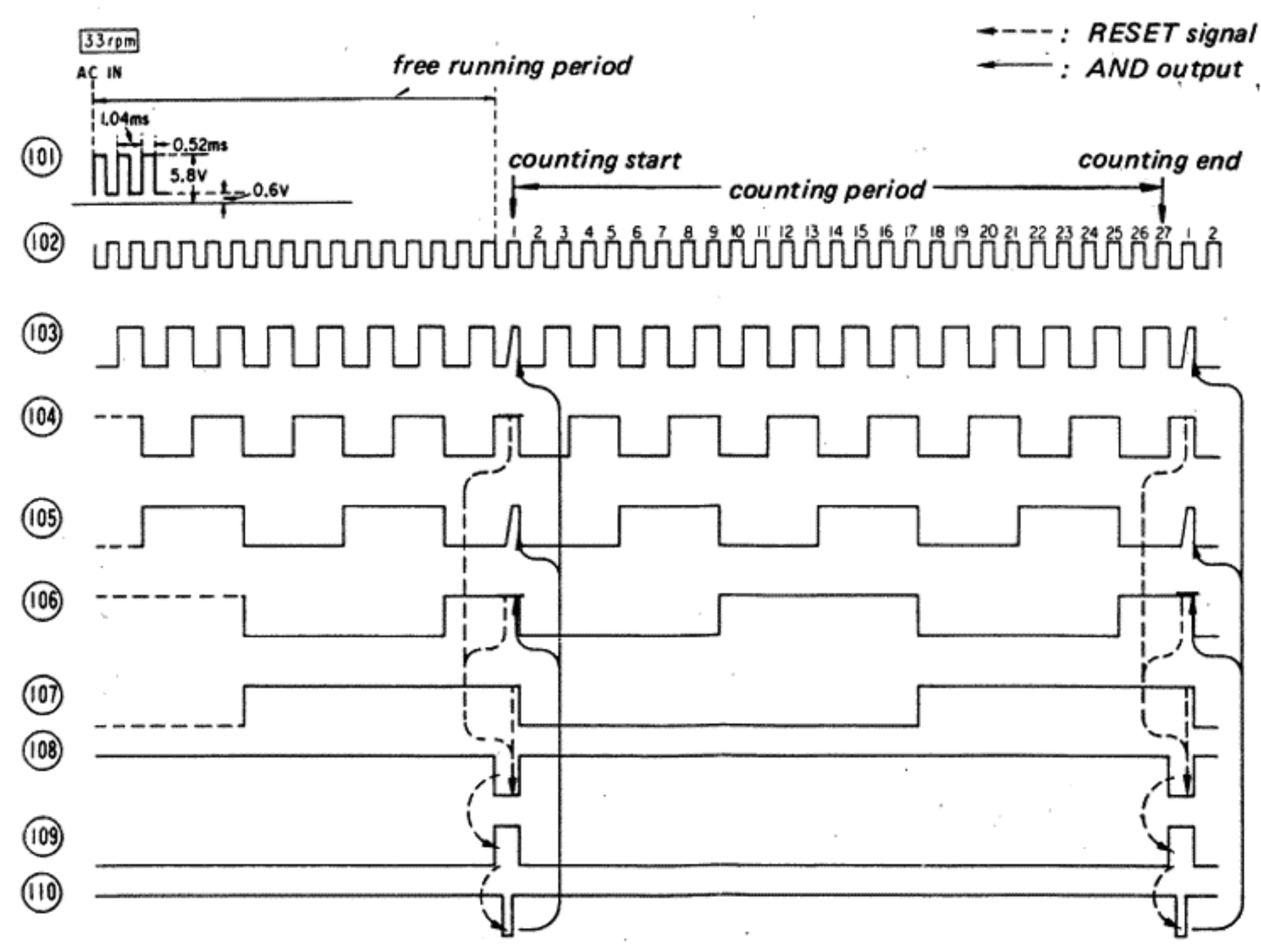
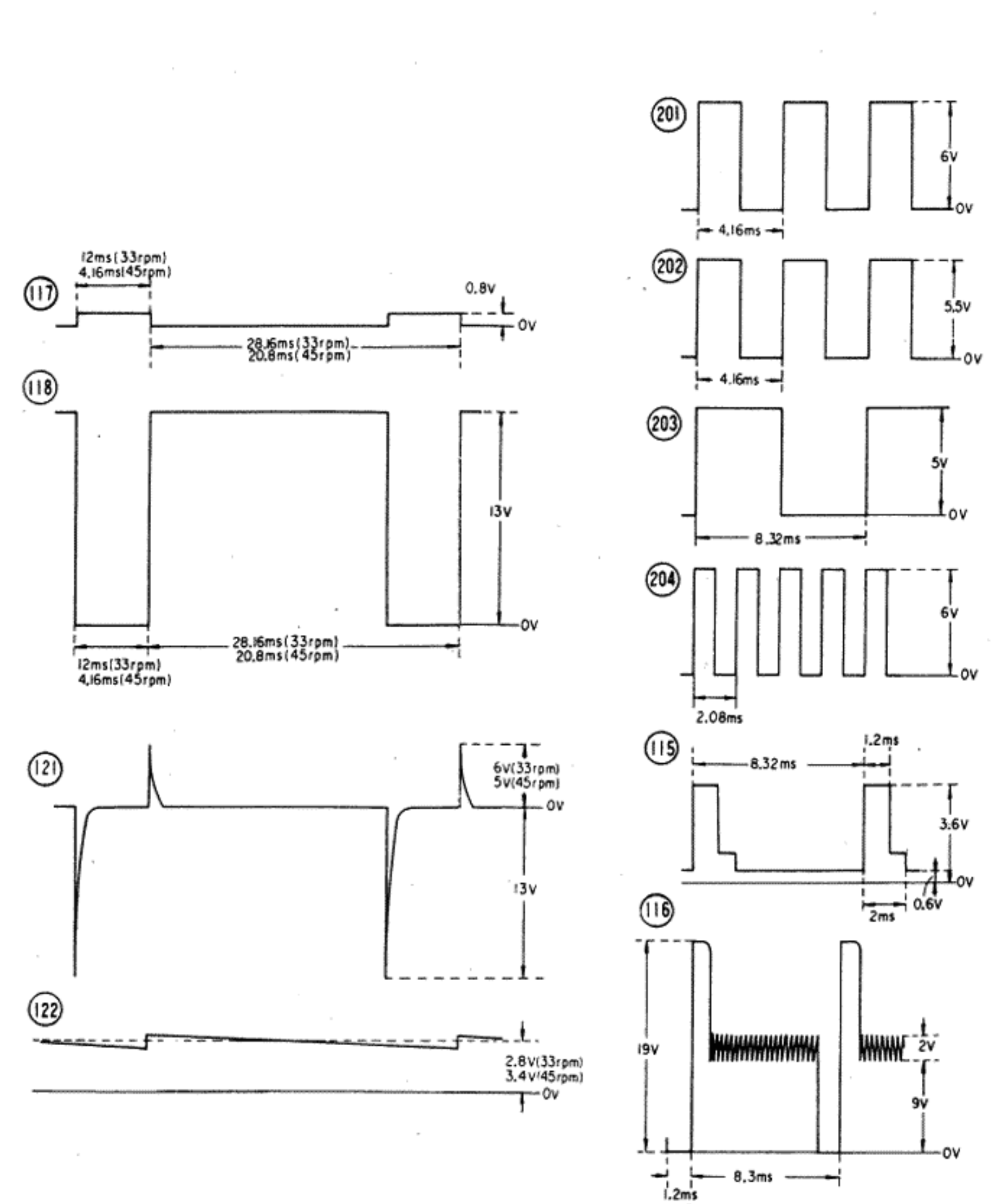
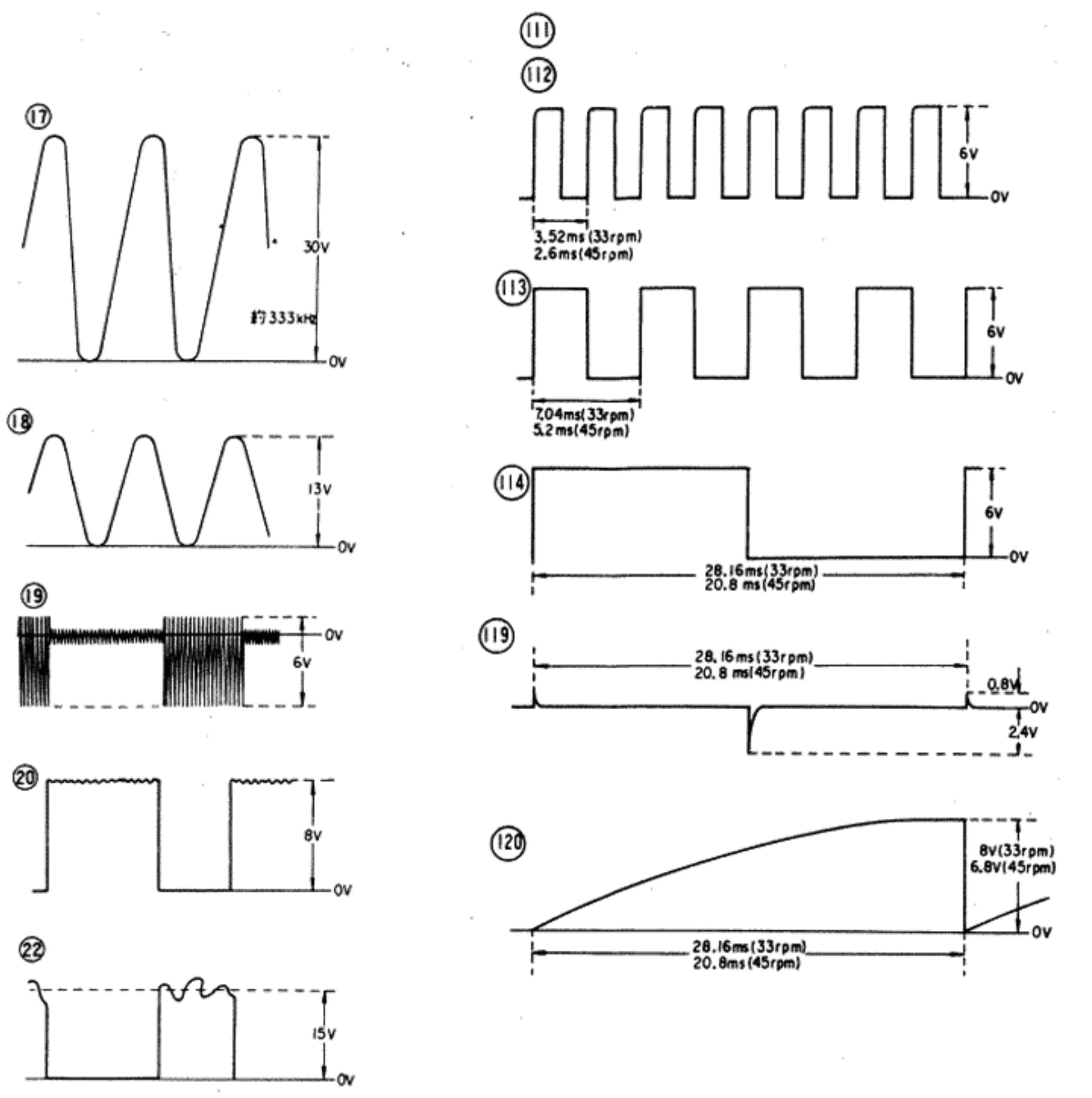
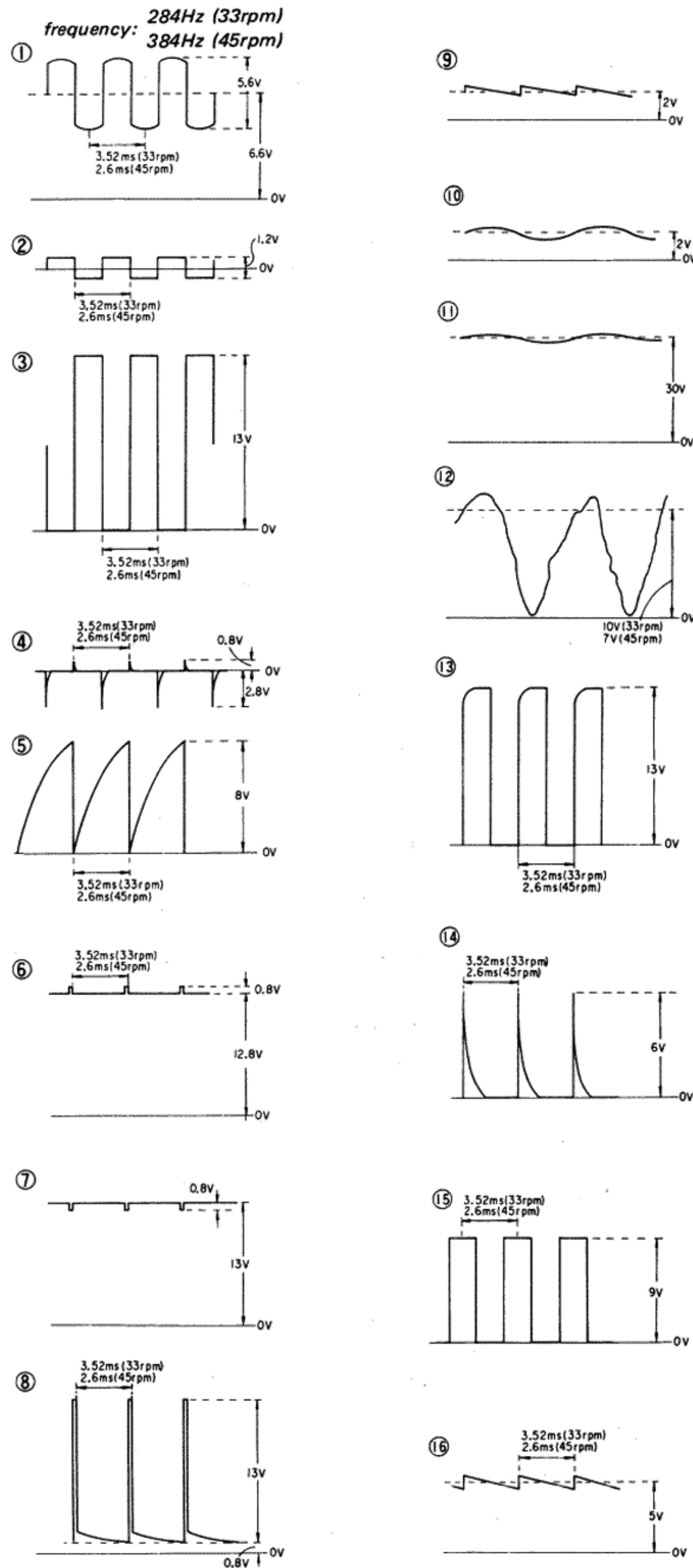

SECTION 5 EXPLODED VIEWS

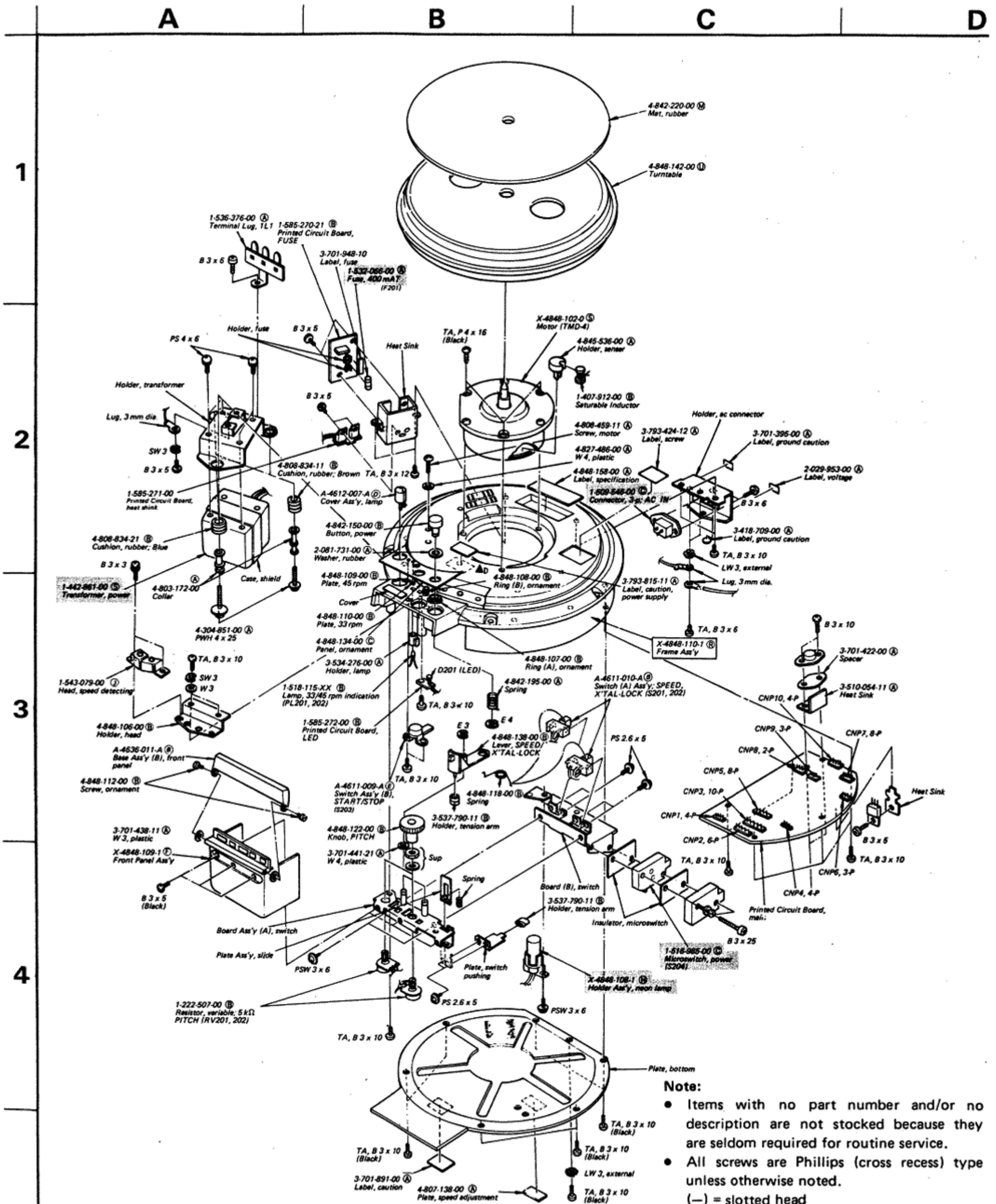

Note:

- Items with no part number and/or no description are not stocked because they are seldom required for routine service.
- All screws are Phillips (cross recess) type unless otherwise noted.
(-) = slotted head
- Circled letters (A to Z) are applicable to European models only.

Note: The components identified by shading are critical for safety. Replace only with part number specified.

SECTION 6 ELECTRICAL PARTS LIST

Note: Circled letters (A) to (Z) are applicable to European models only.

<u>Ref. No.</u>	<u>Part No.</u>	<u>Description</u>
PRINTED CIRCUIT BOARDS		
	1-585-270-21 (B)	FUSE
	1-585-271-00	Heat Shink
	1-585-272-00 (A)	LED
SEMICONDUCTORS		
Transistors		
⇒ Q1~4	(B) 2SC634A	
⇒ Q5,6	(C) 2SA678	
⇒ Q7~11	(B) 2SC634A	
⇒ Q12, 13	(C) 2SA678	
⇒ Q14~16	(B) 2SC634A	
⇒ Q17	(C) 2SA678	
⇒ Q18~33	(B) 2SC634A	
Q34	(D) 2SC1061	
Q35	(E) 2SA671	
⇒ Q36~51	(B) 2SC634A	
Q52	(D) 2SC1061	
Q53	(E) 2SA671	
⇒ Q54,55	(B) 2SC634A	
Q56	(D) 2SC1127	
⇒ Q57~60	(B) 2SC634A	
Q61	(D) 2SC1061	
Q62	(E) 2SA671	
⇒ Q63	(B) 2SC634A	
Q64	(C) 2SC1760	
⇒ Q65	(B) 2SC634A	
Q66	(D) 2SC926A	
Q67	(E) 2SC1431	
⇒ Q68	(B) 2SC634A	
Q69	(B) 2SK30A	
Q201,202	(D) 2SC1061	
IC1	(L) MSM5576	
IC2	(E) M53200P	
IC3	(E) M53210P	
IC4,5	(E) M53200P	
IC6	(C) M53220P	
IC7,8	(E) M53200P	

<u>Ref. No.</u>	<u>Part No.</u>	<u>Description</u>
Diodes		
D1~3	(B) 1S1555	
D4	(A) MV5L	
D5	(B) 1S1555	
⇒ D6	(B) EQB01-06	
D7~10	(B) 10E2	
D11~34	(B) 1S1555	
D35	(B) 10E2	
D36~39	(B) 1S1555	
D40~43	(B) 10E2	
⇒ D44	(B) EQB01-06	
D201	(C) SLP24B	
COIL		
L1	1-407-661-XX (A)	470μH, microinductor
TRANSFORMER		
T201	1-442-861-00 (S)	Power
CAPACITORS		
All capacitors are in μF and ceramic unless otherwise noted. 50 WV or less are not indicated except for electrolytics. pF = μμF, elect = electrolytic		
C1	1-108-251-12 (A)	0.1 mylar
C2	1-121-726-11 (A)	0.47 50V
C3	1-121-651-11 (A)	10 16V
C4	1-102-110-11 (A)	220 ceramic
C5,6	1-121-651-11 (A)	10 16V
C7	1-108-227-12 (A)	0.001 mylar
C8	1-130-043-11 (E)	10000P polyethylen ±2%
C9	1-108-227-12 (A)	0.001 mylar
C10	1-121-651-11 (A)	10 16V
C11	1-131-213-11 (B)	0.47 35V tantalum
C12	1-131-215-11 (B)	1 35V tantalum
C13	1-108-361-12 (A)	0.056 mylar
C14	1-121-983-11 (C)	470 35V
C15	1-121-651-11 (A)	10 16V
C16	1-121-726-11 (A)	0.47 50V
C17	1-121-415-11 (B)	100 16V
C18	1-121-984-11 (D)	2200 35V
C19	1-108-251-12 (B)	0.1 mylar
C20	1-121-395-11 (A)	4.7 25V
C21	1-121-651-11 (A)	10 16V

Note: The components identified by shading are critical for safety. Replace only with part number specified.

• ⇒ : Due to standardization, interchangeable replacements may be substituted for parts specified in the diagrams.

Note: Circled letters (A to Z) are applicable to European models only.

Ref. No.	Part No.	Description
C22	1-102-110-11 (A) 220P	ceramic
C23,24	1-121-651-11 (A) 10	16V
C25	1-108-239-12 (A) 0.01	mylar
C26	1-108-242-12 (A) 0.022	mylar
C27	1-131-213-11 (B) 0.47	35V tantalum
C28	1-108-358-12 (A) 0.018	mylar
C29,30	1-121-726-11 (A) 0.47	50V
C31,32	1-121-480-11 (A) 22	25V
C33	1-108-239-12 (A) 0.01	mylar
C34	1-121-479-11 (A) 22	16V
C35	1-108-239-12 (A) 0.01	mylar
C36,37	1-123-228-11 (B) 1	50V
C38	1-108-239-12 (A) 0.01	mylar
C39	1-121-391-11 (A) 1	50V
C40,41	1-108-555-12 (A) 0.001	mylar
C42	1-108-239-12 (A) 0.01	mylar
C43	1-108-251-12 (B) 0.1	mylar
C44	1-108-239-12 (A) 0.01	mylar
C45,46	1-121-726-11 (A) 0.47	50V
C47,48	1-121-480-11 (A) 22	25V
C49,50	1-102-491-11 (A) 51P	
C51	1-131-195-11 (B) 33	10V tantalum
C52	1-101-919-11 (A) 0.0022	
C53,54	1-102-967-11 (A) 22P	ceramic
C55	1-108-239-12 (A) 0.01	mylar
C56~65	1-102-959-11 (A) 22P	ceramic
C66	1-121-651-11 (A) 10	16V
C67,68	1-121-726-11 (A) 0.47	50V
C69,70	1-121-480-11 (A) 22	25V
C71	1-108-239-12 (A) 0.01	mylar
C72~77	1-102-967-11 (A) 22P	ceramic
C78	1-131-195-11 (B) 33	10V tantalum
C79	1-101-919-11 (A) 0.0022	
C80	1-121-262-11 (B) 10	250V
C81	1-121-391-11 (A) 1	50V
C82	1-101-001-11 (A) 0.001	
C83	1-161-032-11 (A) 0.01	ceramic boundary layer

Ref. No.	Part No.	Description
RESISTORS		
All resistors are in ohms. Common 1/4 W carbon resistors are omitted. Check schematic diagram for values.		
R10	1-202-553-11 (A) 150	1/2W composition
R15	1-213-201-11 (B) 390k	1/4W metal oxide
R16	1-224-255-XX (C) 100k	adjustable
R17	1-213-201-11 (B) 390k	1/4W metal oxide
R18	1-224-255-XX (C) 100k	adjustable
R21	1-202-553-11 (A) 150	1/2W composition
R24,25	1-213-198-11 (B) 6.8k	1/4W metal oxide
R28	1-213-199-11 (B) 10k	1/4W metal oxide
R47	1-217-393-11 (B) 33	1/4W fuse
R49	1-224-252-XX (C) 10k	adjustable
R94,95		
R132, 133	1-202-569-11 (A) 680	1/2W composition
R164, 165		
R177	1-217-393-11 (B) 33	1/4W fuse
R181	1-212-849-11 (A) 4.7	1/4W fuse
R183	1-206-664-11 (A) 1k	2W metal oxide
RV201,202	1-222-507-00 (B) 5k	variable; PITCH
SWITCHES		
S201,202	A-4611-010-A (B) Switch (A) Ass'y, SPEED, X'TAL-LOCK	
S203	A-4611-009-A (E) Switch (B) Ass'y, START/STOP	
S204	1-516-985-00 (C) Microswitch, POWER	
MISCELLANEOUS		
CP201	1-101-534-31 (C) Encapsulated Component, C-R	
F201	1-532-066-00 (B) Fuse, 400 mA	
H201	1-543-079-00 (J) Head, speed detecting	
NL201	X-4848-108-1 (H) Holder Ass'y, neon lamp	
M201	X-4848-102-0 (S) Motor Ass'y, TMD-4 including;	
	1-407-912-00 (B) Microinductor, 470μH	
PL201,202	1-518-115-XX (B) Lamp, 33/45 rpm indication; 6V 35mA	
X-1	1-527-903-00 (I) X'tal, osc	
	1-407-912-00 (B) Saturable Inductor	
	1-509-546-00 (D) Connector, 3-p, AC IN	
	1-535-100-00 (A) Faston Resepectacle	
	1-536-378-XX (A) Terminal Lug, 1L1	

Note: The components identified by shading are critical for safety. Replace only with part number specified.

Note: Circled letters (A to Z) are applicable to European models only.









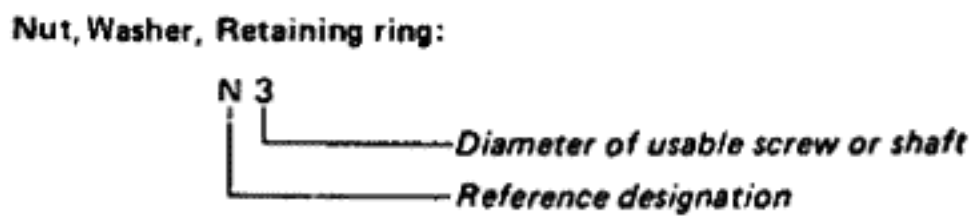
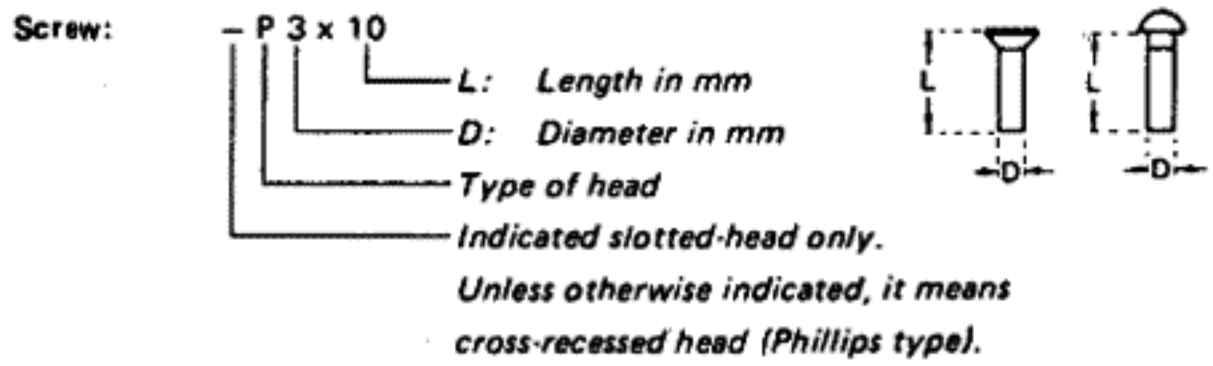



ACCESSORIES & PACKING MATERIALS











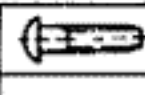

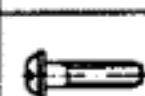
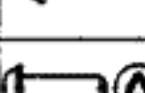
<u>Part No.</u>	<u>Description</u>
X-4845-105-0	Ⓢ Cushion (A) Ass'y
X-4848-107-0	Ⓒ Cushion (C) Ass'y
X-4848-113-0	Carton Ass'y
X-4848-114-0	Ⓔ Cushion (D) Ass'y
1-534-819-00	Ⓒ Cord, power
3-701-630-00	Ⓐ Bag, plastic
3-780-991-11	Ⓚ Manual, instruction
3-780-867-11	Ⓐ Manual, instruction
3-794-008-11	Ⓔ Leaflet, mounting diagram
3-849-790-00	Ⓑ Bag, protection
4-808-461-00	Ⓔ Adaptor, 45 r.p.m.
4-848-145-00	Ⓒ Bag, protection
4-848-146-00	Ⓑ Sheet, protection
4-848-153-00	Ⓑ Washer, ornament
4-848-153-00	Ⓐ Bag, plastic
4-848-157-00	○ L-shaped Hexagonal Wrench

Note: The components identified by shading are critical for safety. Replace only with part number specified.

HARDWARE NOMENCLATURE



Reference Designation	Shape	Description	Remarks
SCREWS			
P		pan-head screw	binding-head (B) screw for replacement
PWH		pan-head screw with washer face	binding-head (B) screw and flat washer for replacement
PS PSP		pan-head screw with spring washer	binding-head (B) screw and spring washer for replacement
PSW PSPW		pan-head screw with spring and flat washers	binding-head (B) screw and spring and flat washers for replacement
R		round-head screw	binding-head (B) screw for replacement
K		flat-countersunk-head screw	
RK		oval-countersunk-head screw	
B		binding-head screw	
T		truss-head screw	binding-head (B) screw for replacement
F		flat-fillister-head screw	
RF		fillister-head screw	
BV		braizer-head screw	

Reference Designation	Shape	Description	Remarks
SELF-TAPPING SCREWS			
TA		self-tapping screw	ex: TA, P 3 x 10
PTP		pan-head self-tapping screw	binding-head self-tapping (TA, B) screw for replacement
PTPWH		pan-head self-tapping screw with washer face	binding-head self-tapping (TA, B) screw and flat washer for replacement
PTTWH		pan-head thread-rolling screw with washer face	binding-head (B) screw and flat washer for replacement
SET SCREWS			
SC		set screw	
SC		hexagon-socket set screw	ex: SC 2.6 x 4, hexagon socket
NUT			
N		nut	
WASHERS			
W		flat washer	
SW		spring washer	
LW		internal-tooth lock washer	ex: LW3, internal
LW		external-tooth lock washer	ex: LW3, external
RETAINING RINGS			
E		retaining ring	
G		grip-type retaining ring	

TTS-8000

9-958-349-11

Sony Corporation

© 1977

- 22 -

7D0216-1
Printed in Japan